

Outline principle

F1245 with active cooling (floating condensing)

Application

Houses with water-borne heating systems and cooling requirements.

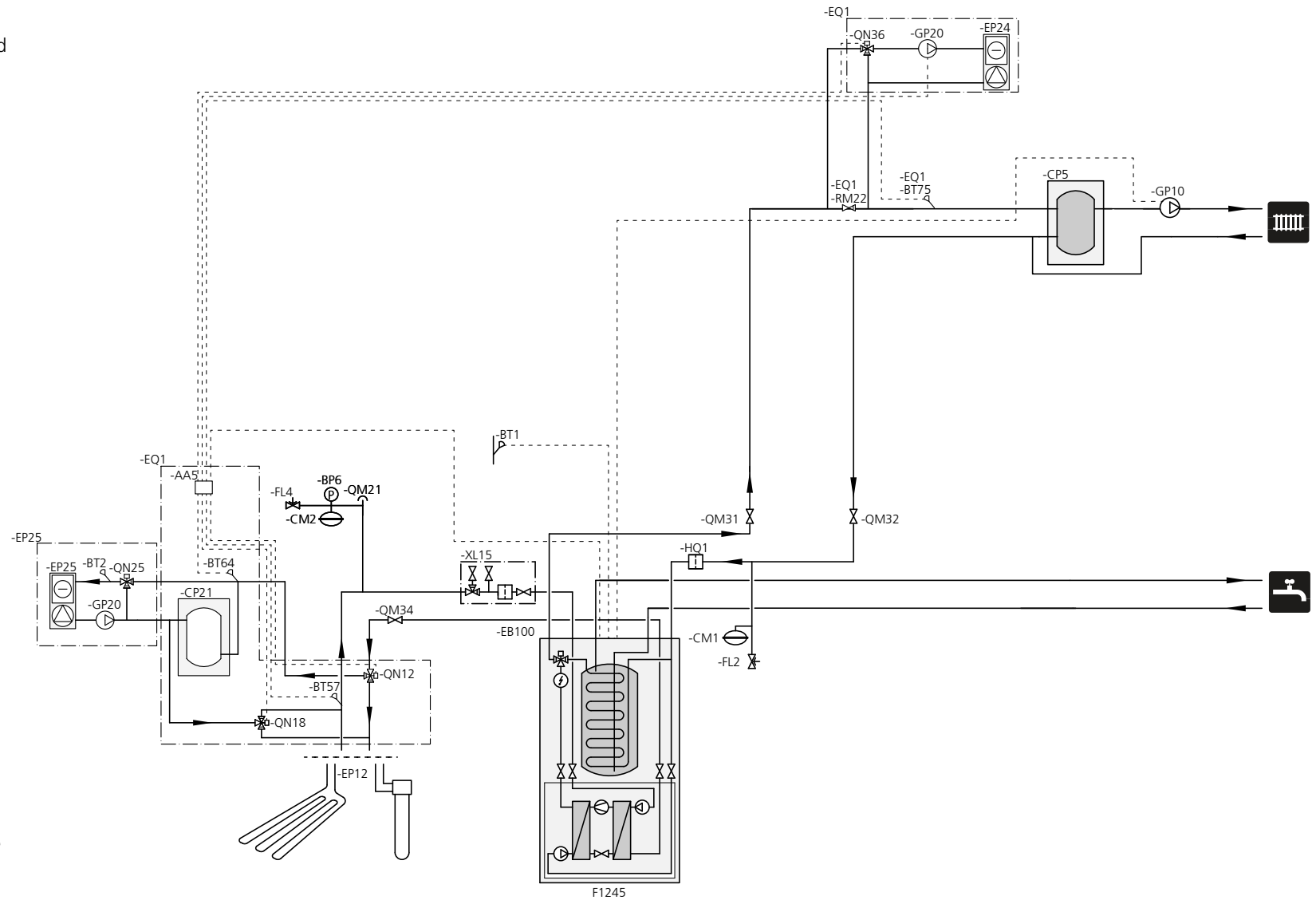

NOTE! This is an outline diagram. Actual installation must be designed according to applicable norms.

For more information refer to the appropriate "Installer manual" and/or "Installation and Maintenance Instructions".

Designations according to standard IEC 81346-1 and 81346-2.



Operating modes

Heat production

F1245 is equipped with an outdoor temperature controlled heating control system. This means that the supply of heat to the house is regulated in accordance with the chosen setting of the regulating curve (curve slope and offset). After adjustment, the correct amount of heat for the outdoor temperature is supplied. The supply temperature of the heat pump will hunt around the required value. For subnormal temperatures the control system calculates a heating deficit in the form of "degree minutes", which means that heating production is accelerated. The larger the subnormal temperature, the greater the heat production. The internal immersion heater is connected automatically when the energy requirement exceeds the heat pump's capacity.

Hot water production

If the water heater is docked to F1245 when there is a demand for hot water, the heat pump gives this priority and devotes its entire output to hot water heating. No room heat is produced in this mode. Maximum time for hot water charging can be adjusted in the menu system. Hot water charging starts when the hot water sensor has fallen to the set start temperature. Hot water charging stops when the hot water temperature on the hot water sensor (BT6) has been reached. For occasional higher demand for hot water, the "temporary lux" function can be used to raise the temperature for 3 – 12 hours (selected in the menu system). Periodic hot water increase is factory set to every 14 days.

Passive/active cooling (4-pipe)

This function requires a reversing valve for cooling, circulation pump, shunt valve and the ACS 45 accessory.

This function makes both heat and cooling production independently of each other possible.

The cooling system supplies cooling from the brine circuit using a circulation pump via a shunt

valve.

Passive cooling occurs without the compressor running, while active cooling occurs when the compressor is running.

For the installation to work the heating medium must flow freely, for example using UKV.

Operating mode cooling is activated by the temperature of the outdoor temperature sensor and any room sensors or room units.

When cooling is required the cooling reversing valve and the circulation pump are activated. The shunt regulates according to the cooling sensor and a cooling set point value that is determined by the selected cooling curve and offset. Degree minutes are calculated in response to the value on the brine out external temperature sensor and the cooling set point value. The degree minute value determines in which cooling mode the installation is according to the menu settings.

Functions/accessories

Heat pump

The compressor in a F1245 is the on/off type. The entire compressor output is routed to heating, hot water or pool heating if applicable. If the output is not sufficient, additional heat engages automatically.

AUX inputs

F1245 has software controlled inputs for connecting the switch function or sensor. This means that when an external switch function or sensor is connected to one of five AUX connections, the correct function must be selected for the correct connection. For further information see the Installer manual.

The following functions can be controlled:

- Temperature sensor, hot water top
- Temperature sensor, cooling/heating
- Blocking of additional heat and/or compressor

- Blocking heating
 - Tariff blocking
 - Switch for "SG ready"
 - Forced control of brine pump
 - Activating temporary lux (extra hot water)
 - External adjustment of the supply temperature
 - Activating fan speed (requires accessory NIBE FLM)
 - NV 10, pressure/level/flow monitor brine
- All control signals should occur with potential-free relays.

AUX outputs

It is possible to have an external connection through the relay function via a potential-free variable relay (max 2 A) on the input board (AA3), terminal block X7.

Optional functions for external connection:

- Indication of common alarm (preselected at the factory).
- Controlling ground water pump.
- Cooling mode indication (only applies if cooling accessories are available).
- Control of circulation pump for hot water circulation.
- External circulation pump (for heating medium).
- External reversing valve for hot water.

If any of the above is installed to terminal block X7 it must be selected in the control system.

The accessory board is required if two or more of the above functions are to be connected to terminal block X5 at the same time.

Room control

F1245 can be supplemented with a room sensor (BT50).

The room sensor has up to three functions:

- Show current room temperature in the heat

pump's display.

- Provides the option of changing the room temperature in °C.
- Provides the option to change/stabilise the room temperature.

Install the sensor in a neutral position where the set temperature is required. A suitable place is on a free inner wall in a hall approx. 1.5 m above the floor. It is important that the sensor is not prevented from measuring the correct room temperature by being located, for example, in a recess, between shelves, behind a curtain, above or close to a heat source, in a draft from an external door or in direct sunlight. Closed radiator thermostats may also cause problems.

The heat pump operates without the sensor, but if one wishes to read off the accommodation's indoor temperature in F1245's display the sensor must be installed.

External circulation pump

With the AXC 40 accessory (an AXC 40 for each accessory function that is to be used) an external circulation pump (for the climate system) can be connected to the heat pump if the alarm relay (AUX output) is activated for another function. The function is already included in the following accessory functions:

- Step controlled additional heat
- Shunt controlled additional heat
- Pool

List of Components

F1245 with active cooling (floating condensing)

Pos	Name	Specification	Manufacturer	Art no.	Remarks
EB100	Heat pump	F1245	NIBE		
XL15	Filling set, HTF	HTF R25/G32	NIBE	089368/089971	HTF R25 (max 12 kW), HTF G32 (max 30 kW)
CM2	Level vessel HTF		NIBE		Level vessel at open system. Level vessel included in F1245.
FL3	Valve, Safety, HTF		NIBE		Included in F1245
HQ1	Particle filter HM		NIBE		Included in F1245
BT1	Temp.sensor, Outdoor		NIBE		Included in F1245
CM3	Expansion vessel HTF				Expansion vessel at closed system.
EP12	Collector, HTF				
BP6	Manometer, HTF				
QM12	Filling valve, HTF				
QM21	Vent valve, HTF				
QM34	Shut off valve, HTF-f				
QM42	Shut off valve, HTF-r				
CM1	Expansion vessel, closed, HM				
FL2	Safety valve, HM				
QM31	Shut off valve, HM-f				
QM32	Shut off valve, HM-r				
GP10	Circulation pump, HM external				
EQ1	Passive/active cooling 4-pipe				
AA5	Accessory board	ACS 45	NIBE	067195	
BT57	Temperature sensor, collector				
BT64	Temperature sensor, supply line cooling				
BT75	Temperature sensor, supply line after heating dump				
CP21	Volume vessel	NIBE UKV	NIBE		UKV vessel must be condensation insulated.
EP24	Exchanger				
GP20	Circulation pump				
QN12	Reversing valve, cooling/heating				Rec runtime 30-120 secs.
QN18	Shunt valve, cooling				Rec runtime 60-120 secs.
QN36	Shunt valve, heating dump				Rec runtime 60-120 secs.
RM22	Non-return valve				
CP5	Buffer vessel (UKV)	UKV 100/200/300/500	NIBE		Size varies depending on heat pump and system volume.

